

OPTIMAL POWER[®]

OC Automation Converters Series

Electronic Industries Alliance (EIA) interface converter series for serial communication devices

Model No. OC485-422
EIA standard RS-485 to RS-422 Bi-directional Converter

RS422↔RS485 Serial Converter

Data Sheet

Revision B

www.optimal-power.com

PROPRIETARY DATA

All data in this datasheet is proprietary and may not be disclosed, duplicated or used for procurement or manufacturing purposes, without prior written permission by
OPTIMAL POWER SUPPLIES LLC

LIABILITY

DO NOT OPERATE OR SERVICE THE OC485-422 MODEL WITHOUT READING THE ENTIRE CONTENT BELOW

Optimal Power Supplies LLC is not responsible for any kinds of damages sustained through the use of this or any other Optimal Power Supplies LLC products.

WARRANTY

Optimal Power warrants all of its products against defects in materials and workmanship for one year from date of delivery. We will repair, or replace parts which prove to be defective during the warranty period provided that:

1. A Return Maintenance Authorization (RMA) is obtained from OPTIMAL POWER at (251) 209-8088 or www.optimal-power.com. Please reference your RMA number on the outside of the box the item is shipped in.
2. Shipping charges are pre-paid by customer.

Optimal Power does not endorse any other warranty, expressed or implied, and is not liable for consequential damages. Products that are damaged, opened, or modified do not qualify for a warranty. All terms specified in our website are final. Terms are subject to change. The same procedures must be followed for repairs outside the warranty period.

OC Automation Converter Series

Model No. OC485-422

Main Features

- Din Rail Mountable
- Highly Efficient Design
- Compact & Low Profile
- 2.57" H x 2.76" W x 4.43" D
- EIA RS422 / RS485 Standards
- Bi-directional Serial Communication
- LED Indicators for Data Transmission
- Easy Installation Plug and Play Device
- Durable UL94V-0 Rated ABS Plastic Housing
- Easy Access Terminal Screw Wiring Connections
- Versatile +5V DC to +24V DC Power Supply Input
- Cutting edge, Cost Effective and Reliable Industrial Automation Solution



Specifications

Electrical

Bi-directional I/O	EIA422 and RS422 Standards (Full Duplex)
Bi-directional I/O	EIA485 and RS485 Standards (Full Duplex 4-wire)
Distance	Up to 4000 ft. (1250 meters)
Format	Asynchronous data only
Speed	Data rate up to 115KHz
Mounting	Din rail (Snap in)
Interface Connections	Terminal block screw in connectors
Input Voltage	Versatile DC input voltage range of +5V to +24V
Input Current	Not more than 100mA

Physical

Dimensions	Compact (2.57" H x 2.76" W x 4.43" D)
Weight	Approx. 0.375 lb = 0.17kg = 6 oz

Environmental

Temperature	0 – 65°C (32 – 150°F)
Humidity	10- 90% non-condensing

Dimensional Figure

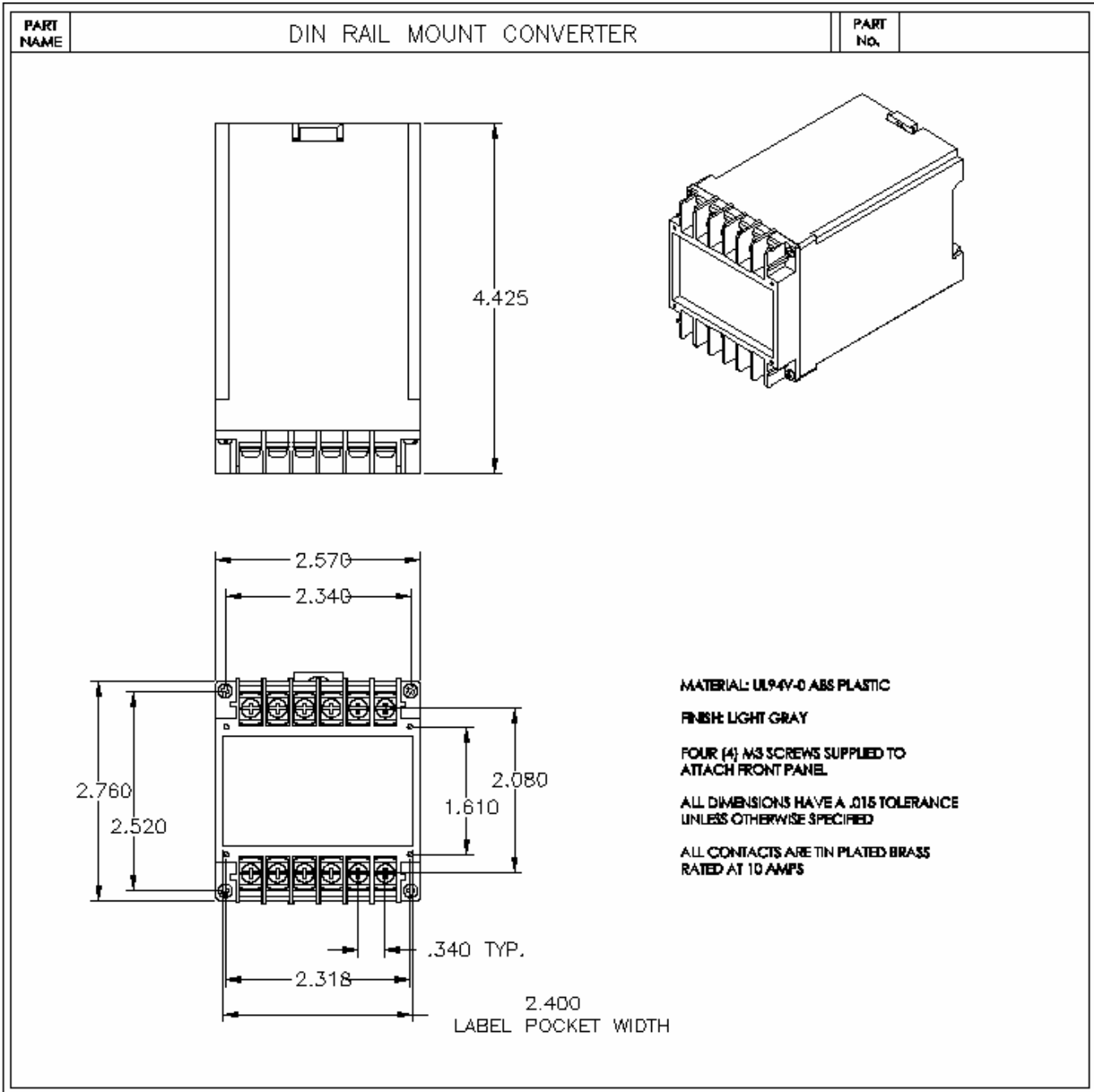

RS422/RS485 Connections

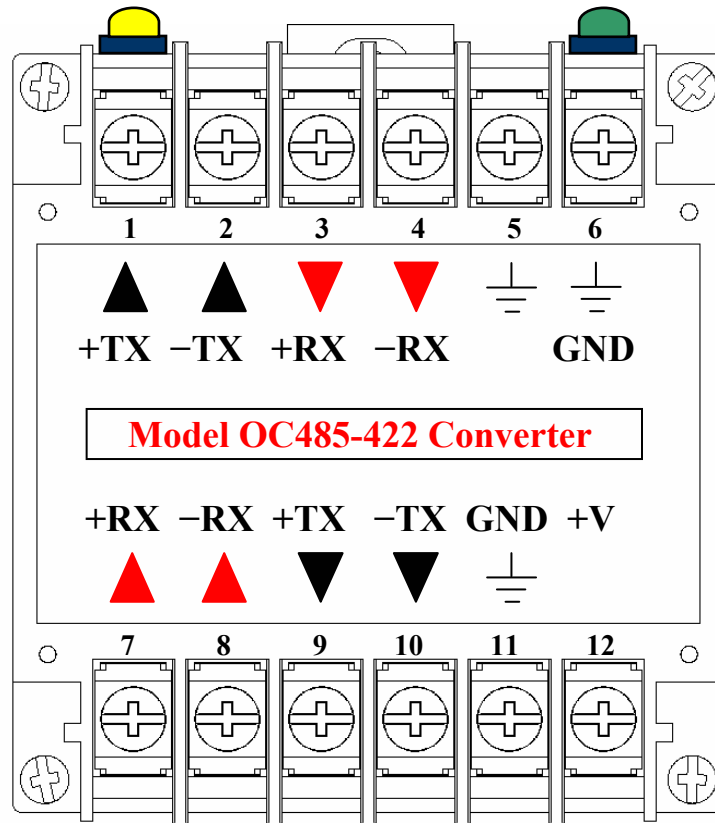

While making connections, ENSURE THAT ALL DATA TERMINALS ARE SCREWED IN TIGHTLY. Loose connections can cause data transmission errors.

Pin Number	Symbol	Description	Data Direction
1	+TX	RS422	Output
2	-TX	RS422	Output
3	+RX	RS422	Input
4	-RX	RS422	Input
5	GND	Signal Ground	Ground**
6	GND	Signal Ground	Ground**
7	+RX	RS485	Input
8	-RX	RS485	Input
9	+TX	RS485	Output
10	-TX	RS485	Output
11	GND	Power Input Ground	Power Input*
12	+V	+5V to +24V DC	Power Input*

FOR PROPER CONNECTION MAKE SURE ALL THE TERMINAL PINS ARE SCREWED IN TIGHTLY

Note*

WARNING: Observe polarity when making the power and data connections. DO NOT supply power to the unit until all the necessary connections to the Model OC485-422 are well secured. Product may get damaged if the power supply polarity is reversed. Nominal voltage of 12V recommended.

Note**

For proper data transmission it is important to connect the Ground Terminal to the user equipment Signal Ground

LED Indicator Description

Green LED: When lit indicates data being transmitted from RS422 to RS485 as shown;

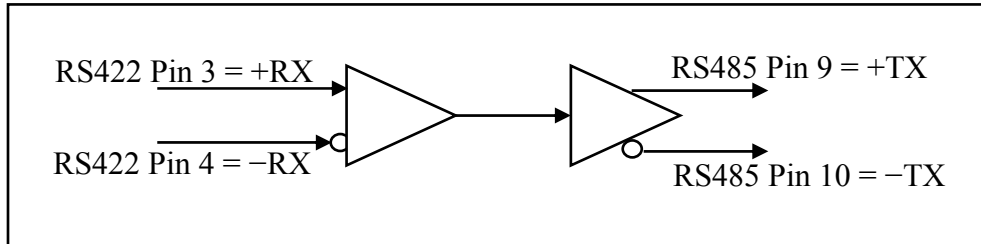

Yellow LED: When lit indicates data being transmitted from RS485 to RS422 as shown;

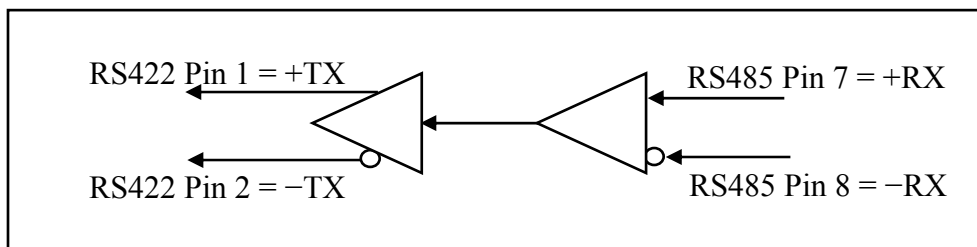

Trouble Shooting

If for some reason the Model OC485-422 does not work and there is no LED lit then;

1. Make sure all the power, signal ground, and data connections are securely screwed in.
2. Make sure that there are NO reverse polarity connections on the unit.
3. If only the Green LED is not lit, then check the connections on pin 3 & 4 for RS422 data input and verify that there is a signal going into the Model OC485-422.
4. If only the Yellow LED is not lit, then check the connections on pins 7 and 8 for RS485 data input and verify that there is a signal going into the Model OC485-422.
5. If the Green and Yellow LEDs are lit and still there is no data transmission, then verify pins 1 and 2 for RS422 data output and pins 9 and 10 for RS485 data output.
6. Finally, verify that the end-user RS485 network has the required impedance for the system level circuit. If the system does NOT require 120Ω impedance then disconnect all the connections from the Model OC485-422 and move the internal jumper J3 to position 1 & 2 as shown on page 7. In most cases, Model OC485-422 is a plug and play device. **DO NOT** change the jumper position unless it is absolutely required.
7. If the unit still does not operate please contact Optimal Power technical support at 251-209-8088 x 22 or at sales@optimal-power.com

Internal Jumper Locations

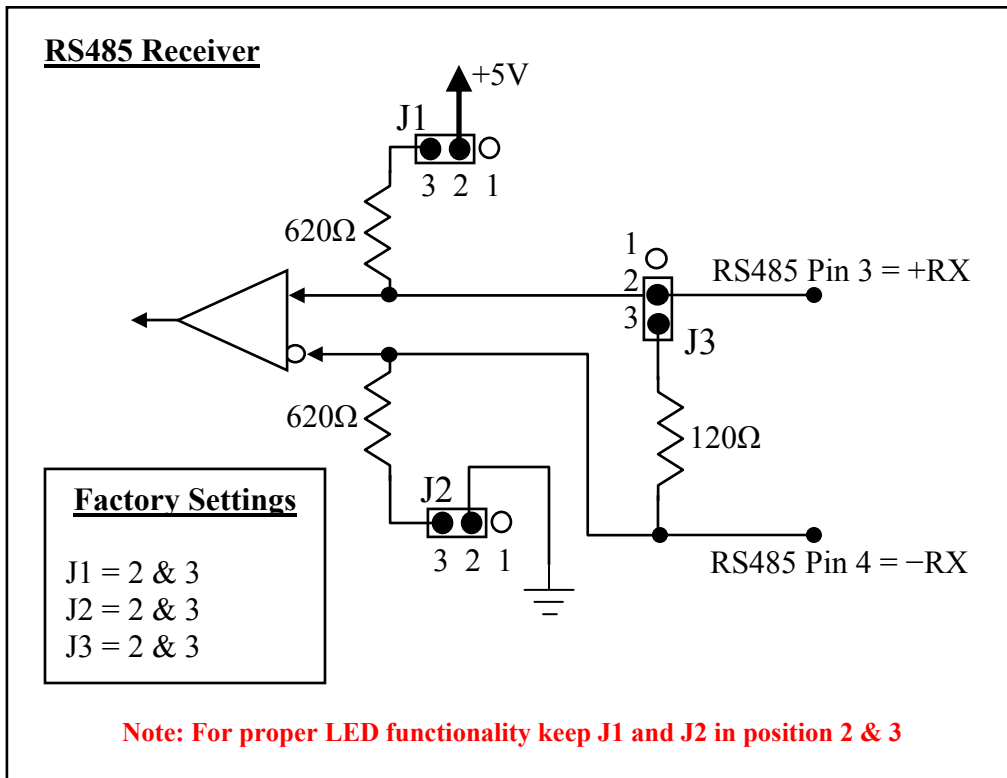
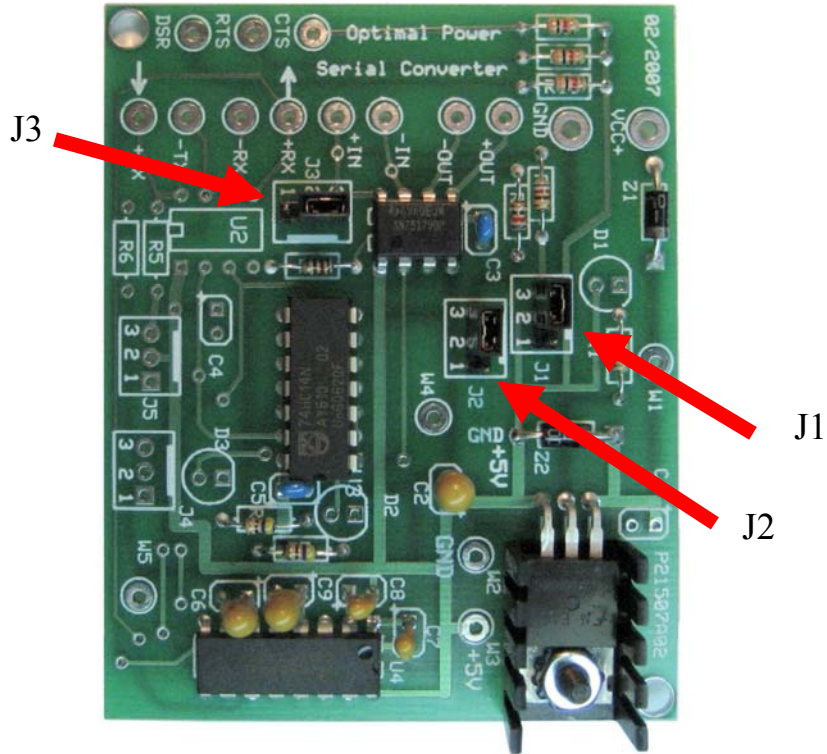

Din Rail Installation Picture

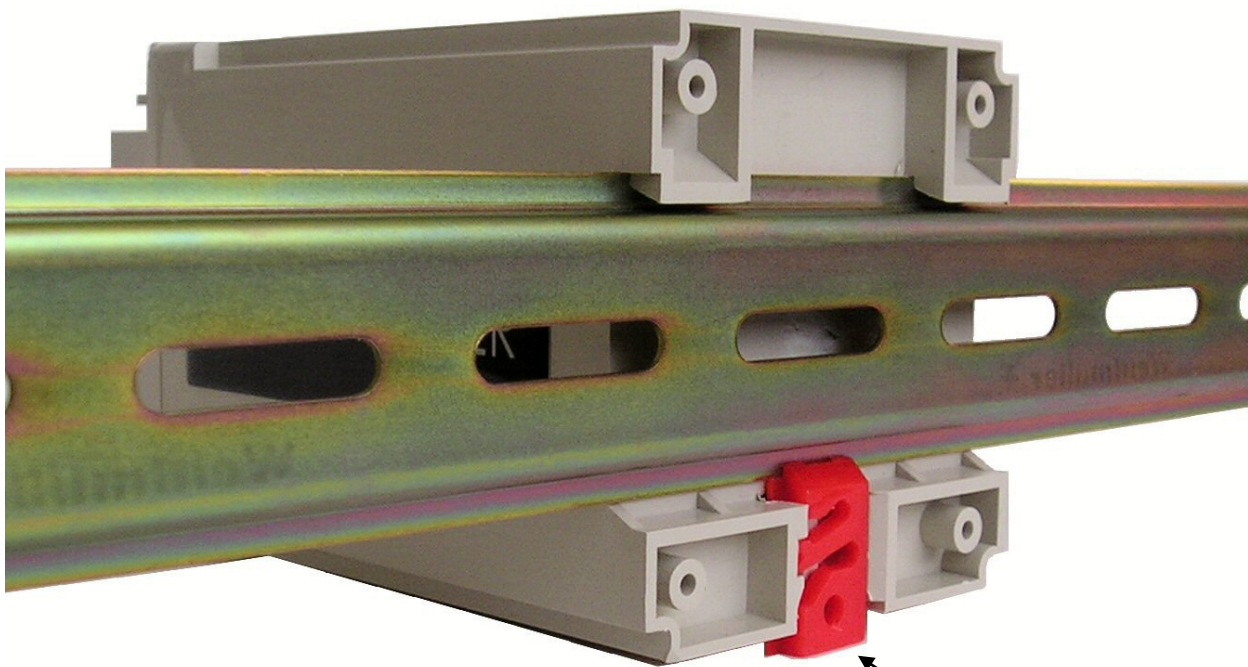

In order to release the unit from the din rail pull down the Red Release Tab with a small screw driver and pull the unit upward.

DO NOT apply excessive force on the unit during din rail snap in installation and removal.

Warnings

To reduce the risk of fire, electric shock or product damage, **DO NOT** expose the OC485-422 unit to direct heat, rain, moisture, dripping or splashing. **DO NOT** place any object filled with any kinds of liquids on the unit. To prevent any damage to the unit's enclosure, **DO NOT** apply excessive force on the unit during din rail snap in installation. **DO NOT** remove any panel cover of the Model OC485-422 while the unit is powered up and running. **Hazardous High Voltages inside!**

Optimal Power Supplies LLC is not responsible for any kinds of damages sustained through the use of this or any other Optimal Power Supplies LLC products.