

# OPTIMAL POWER<sup>®</sup>

## **REDUNDANT POWER SUPPLY SYSTEM FOR NETGEAR<sup>®</sup> RPS CAPABLE ETHERNET SWITCHES**

**MODEL No. OPN300-48SN**

Single-Port –48V DC Output RPS System

Manual

Revision D

July 2008

Optimal Power Supplies LLC  
[www.optimal-power.com](http://www.optimal-power.com)

## **PROPRIETARY DATA**

All data in this manual is proprietary and may not be disclosed, duplicated or used for procurement or manufacturing purposes, without prior written permission by  
**OPTIMAL POWER SUPPLIES LLC**

## **LIABILITY**

**DO NOT OPERATE OR SERVICE THE OPN300-48SN MODEL WITHOUT READING THIS ENTIRE MANUAL FIRST**

Optimal Power Supplies LLC is not responsible for any kinds of damages sustained through the use of this or any other Optimal Power Supplies LLC products. It is entirely the customer's responsibility to take all the necessary precautionary measures when installing this unit.

In the interest of improving internal design, operational function, and/or reliability, Optimal Power Supplies LLC reserves the right to make changes to the products described in this document without notice.

## **WARRANTY**

Optimal Power<sup>®</sup> warrants all of its products against defects in materials and workmanship for one year from date of delivery. We will repair, or replace parts which prove to be defective during the warranty period provided that:

1. A Return Maintenance Authorization (RMA) is obtained from OPTIMAL POWER<sup>®</sup> at (251) 209-8088 or [www.optimal-power.com](http://www.optimal-power.com). Please reference your RMA number on the outside of the box the item is shipped in.
2. Shipping charges are pre-paid.

Optimal Power<sup>®</sup> does not endorse any other warranty, expressed or implied, and is not liable for consequential damages. Products that are damaged, opened, or modified do not qualify for a warranty. The same procedures must be followed for repairs outside the warranty period.

# TABLE OF CONTENTS

CHAPTER	TITLE	PAGE
<b>1</b>	<b>OPN Power Series – Introduction .....</b>	<b>1</b>
1.1	Product Description.....	1
1.2	Main Features.....	1
1.3	General OPN Power Series Specifications.....	2
1.4	Typical Safety Rating.....	2
<b>2</b>	<b>OPN300-48SN.....</b>	<b>3</b>
2.1	OPN300-48SN Description.....	3
2.2	Specifications .....	3
2.3	Typical System Level Setup.....	5
<b>3</b>	<b>Status Indicators and Back Panel Connections.....</b>	<b>6</b>
3.1	Back Panel DC Power Connector.....	6
3.2	Front Panel Status Indicators.....	6
3.3	Compatible NETGEAR® Switch Model Number Table.....	6
3.4	Pin out for OPNC30048 Connection Cable.....	7
3.5	Pin out for OPNC30148 Connection Cable.....	8
<b>4</b>	<b>Alarm Systems.....</b>	<b>9</b>
4.1	Alarm Monitoring System.....	9
<b>5</b>	<b>Installation and Maintenance.....</b>	<b>9</b>
5.1	Installation.....	10
5.2	Maintenance & Safety Instructions.....	12
5.3	Trouble-Shooting Instructions .....	13
5.4	Warnings.....	14
5.5	Limited Warranties and Return Policy.....	14
<b>6</b>	<b>Images.....</b>	<b>15</b>
6.1	OPNC30048 and OPNC30148.....	15

# Chapter 1

## OPN Power Series - Introduction

### 1.1 Product Description

OPN Power Supply Series™ is a unique and a highly reliable power supply series. It is used as a redundant power supply for NETGEAR® RPS capable PoE, 10/100 Ethernet, and Gigabit Ethernet switches. The power supplies in this series are tested and verified by NETGEAR®.

The OPN Power Series™ is designed for Universal AC to DC power supply applications. Because of this feature these power supplies can be used anywhere in the world. These power supplies are mainly used in the following applications:

- Computer Peripherals and Networking Applications
- Telecommunications and Fiber Optic Network
- Voice, Data and Analog Communications
- Universities and Educational Facilities
- Instrumentation and Electronics
- Utility and Power Industries
- Data Acquisition
- Medical
- Military

The OPN Power Series™ is a reliable, efficient and inexpensive solution for all kind of AC to DC power supply applications.

### 1.2 Main Features:

- Compact Rack Mount Size (1.75" H x 19" W x 12.12" D)
- Universal AC (Alternate Current) Input
- Filtered IEC AC Inlet Connectors
- EMI FCC Class B Clearance for Internal Power Bricks
- Single Port Output
- Highly Efficient Design
- 1U Low Profile Height
- NO Minimum Load Required
- Output Voltage Status Indicator
- Cost Effective and Reliable RPS Solution

### 1.3 General OPN Power Series Specifications:

Input Voltage.....	Universal 90VAC to 264VAC
Input Frequency.....	47Hz to 63Hz
Operational Temperature.....	0°C to 55°C
Storage Temperature.....	-20°C to 85°C
Cooling.....	Forced Air / Convection Cooling
Overload Protection.....	Auto-Recovery
Efficiency.....	80-90% Typical
DC OK.....	Status LED

### 1.4 Typical Safety Rating for Internal Power Supply Bricks:

Designed in full compliance with.....	UL60950
	CSA 22.2 No. 234
	EN60950
EMI.....	EN55022 “Class B”
EMS.....	EN61000-4-2,-3,-4,-5,-6,-8,-11
Harmonics.....	EN61000-3-2 Class D



**1U Power Supply**

**Shown above: Model OPN300-48SN**

## 2.1 OPN300-48SN Description:

The Model OPN300-48SN is a 1U rack mountable RPS (Redundant power supply) designed to operate with NETGEAR FSM7352PS, FSM7328PS and FSM7326P Ethernet switches. Model OPN300-48SN has one built-in universal AC to –48V DC power supply with one IEC AC input socket. The Model OPN300-48SN can only be connected to power a single NETGEAR® switch at a time. Model OPN300-48SN is only designed for 300W applications and should not be exceeded\*. The internal power module has its own AC-INLET, ON/OFF switch and associated DC power LED.

## 2.2 Specifications:

### Electrical

Output Voltage	–48VDC
Output Ripple	Typical 100 mV
Output Current	Typical 7A max
Output Power	300W* of single internal power module
Input Voltage	Universal 90VAC to 264VAC input
Input Frequency	47Hz to 63Hz
Input Current	Approx. continuous 3 Amps.
Current Tolerance	1%

\* **NOTE:** The OPN300-48SN only provides up to 300W. If your switch is a FSM7352PS and your POE devices connected to FSM7352PS need more than 300W, then this device is not recommended.

### Typical Safety Ratings for Internal Power Module:

Designed in full compliance with	UL60950 CSA 22.2 No. 234 EN60950
EMI	EN55022 “Class B”
EMS	EN61000-4-2,-3,-4,-5,-6,-8,-11
Harmonics	EN61000-3-2 Class D

### Environmental

Overload Protection	Auto-recovery
Functional Temperature	0 to 70 °C
Storage Temperature	-20 to 85 °C
Over voltage Type	Latch off
Efficiency	80-90% Typical

## Physical

Dimensions	1U (1.75" H x 19" W x 12.12" D)
Weight	Approx. 13.25 lb = 6.01 kg = 212 oz

## Dimensional Figure

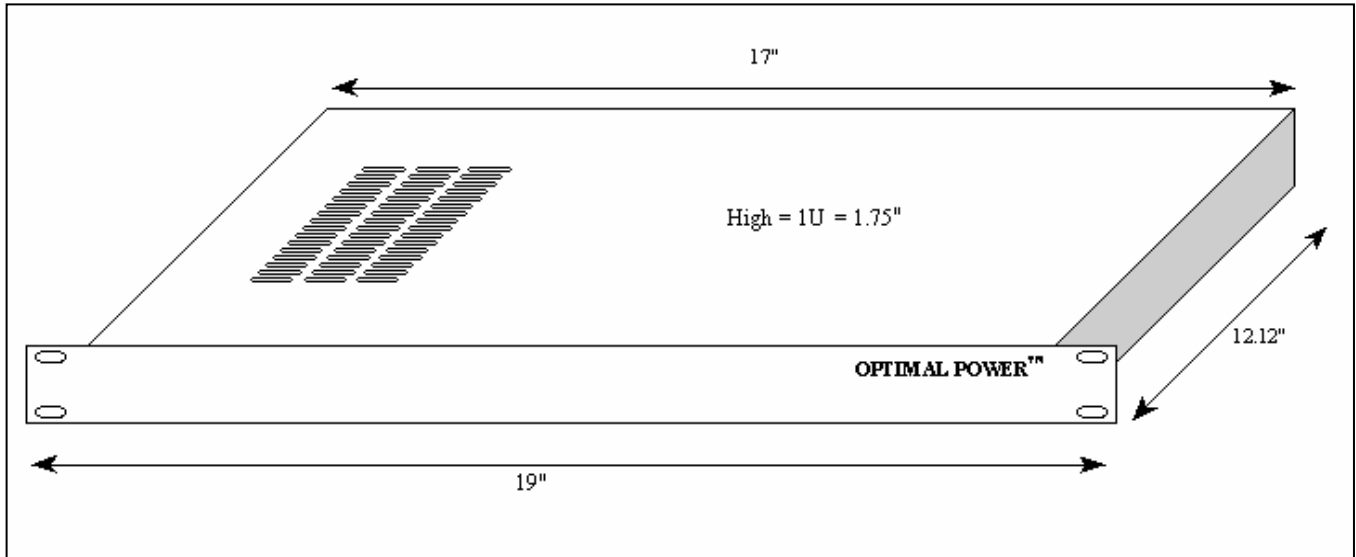

## Overall Rear View



### 2.3 Typical System Level Setup:

An external Optimal Power<sup>®</sup> RPS unit can be connected to a NETGEAR<sup>®</sup> switch to provide redundant power in case the primary power supply connected to the NETGEAR<sup>®</sup> switch fails. The RPS can be setup in different configurations. However, a typical system level setup is as shown:

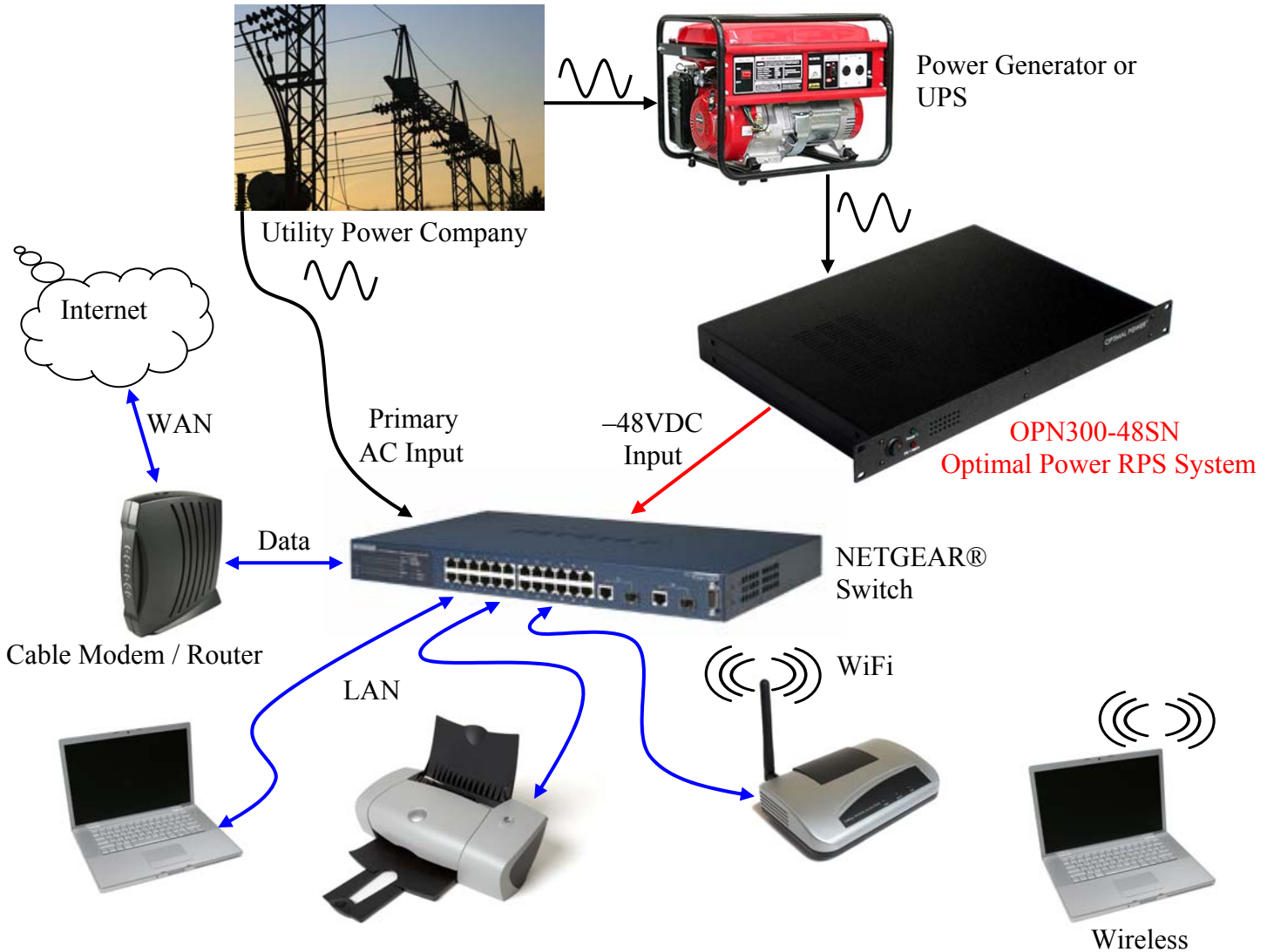

**Status Indicators and Back Panel Connections**

**3.1 Back Panel DC Power Connector for RPS**

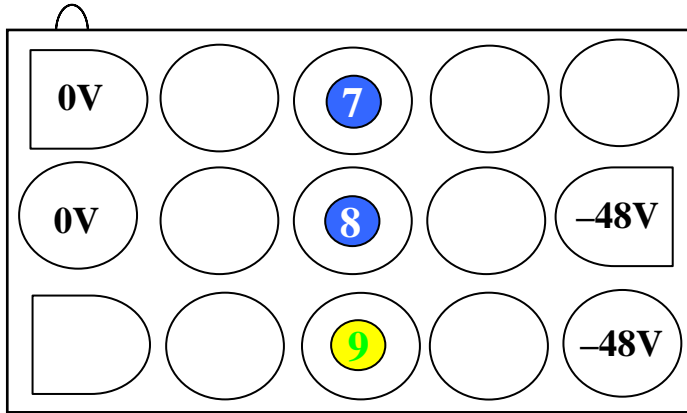

**WARNING:**

**Observe polarity when making connection to the rear of the RPS Model OPN300-48SN**

**Note: Refer to next 2 pages for DC cable connections**

Pin Numbers	Signal Name	Function	
Pin 7	RPS Present	Logic High Not Present	Logic Low Present
Pin 8	RPS ABNORMAL	Logic High Abnormal	Logic Low Normal
Pin 9	Enable	-48V Enabled	0V Disabled

**3.2 Front Panel Status Indicators**

LED	Description
Solid Green	DC Power Supply Status

**3.3 Compatible NETGEAR® Switch Model Number Table**

Model OPN300-48SN RPS is compatible with the following NETGEAR® switches:

NETGEAR® Switch Model	Optimal Power RPS Models	Optimal Power DC Cable	DC Voltages Supported
FSM7326P	OPN300-48SN	OPNC30048	-48V
FSM7352PS	OPN300-48SN	OPNC30148	-48V
FSM7328PS	OPN300-48SN	OPNC30148	-48V

**NOTE:** The OPN300-48SN only provides up to 300W. If your switch is a FSM7352PS and your POE devices connected to FSM7352PS need more than 300W, then this device is not recommended.

### 3.4 Pin-out for OPNC30048 Connection Cable

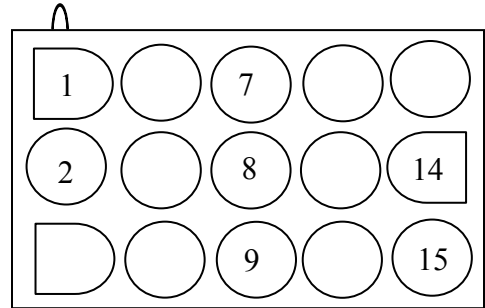
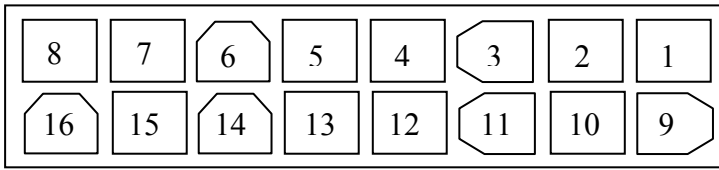

NETGEAR® Switch Side			OPN300-48SN (RPS) Side	
Pin #	Description		Pin #	Description
1	-48V RTN	↔	1	0V
2	N.C.		2	0V
3	ENABLE	↔	3	Not Connected
4	-48V RTN	↔	4	Not Connected
5	SYS POWR FAIL		5	Not Connected
6	-48VDC		6	Not Connected
7	RPS ABNORMAL	↔	7	RPS Present
8	-48VDC	↔	8	RPS ABNORMAL
9	-48V RTN	↔	9	ENABLE
10	N.C.		10	Not Connected
11	-48V RTN	↔	11	Not Connected
12	SECONDARY GND	↔	12	Not Connected
13	N.C.		13	Not Connected
14	-48VDC	↔	14	-48V
15	N.C.		15	-48V
16	-48VDC	↔		

### 3.5 Pin-out for OPNC30148 Connection Cable

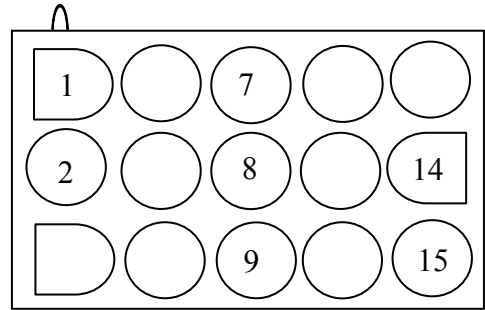
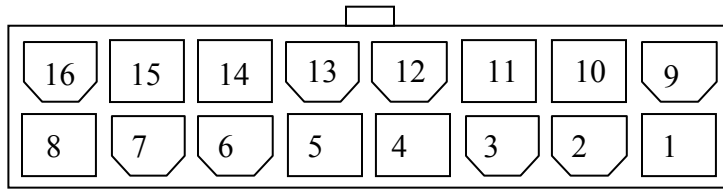

NETGEAR® Switch Side			OPN300-48SN (RPS) Side	
Pin #	Description		Pin #	Description
1	-48V RTN	↔	1	0V
2	-48V RTN	↔	2	0V
3	I Sense		3	Not Connected
4	I2C_SCL		4	Not Connected
5	I2C_SDA		5	Not Connected
6	N/A		6	Not Connected
7	N/A		7	RPS Present
8	N/A		8	RPS GND
9	RPS -48V	↔	9	RPS GND
10	RPS -48V	↔	10	Not Connected
11	N/A		11	Not Connected
12	RPS Power Good		12	Not Connected
13	RPS Present	↔	13	Not Connected
14	RPS GND	↔	14	-48V
15	RPS GND	↔	15	-48V
16	RPS GND	↔		

## **Chapter 4**

### **Alarm Systems**

#### **4.1 Alarm Monitoring System**

The RPS Model OPN300-48SN has the ability to monitor output DC voltage. If the front panel Green LED is ON that indicates good AC input and good DC output. When the Green LED is OFF that indicates the following:

- No AC voltage input
- Low DC voltage output
- No DC voltage output

## **Chapter 5**

### **Installation and Maintenance**

#### **5.1 Installation**

##### **Rack Mounting of Systems**

Observe the following precautions for rack stability and safety. Also refer to the rack installation documentation(s) provided by rack manufacturer. Systems are considered to be components in a rack. Thus, "component" refers to any system as well as to various peripherals, products or supporting hardware. Please adhere to the following instructions when installing the RPS system:

- After installing components in a rack, never pull more than one component out of the rack on its slide assemblies at one time. The weight of more than one extended component could cause the rack to tip over and may result in serious injury.
- Components should be installed in a rack by trained service technicians.
- Do not move racks by yourself. Due to the height and weight of the rack, a minimum of two people should accomplish this task.
- Always load the rack from the bottom up, and load the heaviest item in the rack first.
- Make sure that the rack is level and stable before extending a component from the rack.
- Do not overload the AC supply branch circuit that provides power to the rack. The total rack load should not exceed 80 percent of the branch circuit rating.
- Ensure that proper airflow is provided to components in the rack.
- Do not step on or stand on any component when servicing other components in a rack.
- The system chassis must be positively grounded to the rack cabinet frame. Do not attempt to connect power to the system until grounding cables are connected. Completed power and safety ground wiring must be inspected by a qualified electrical inspector. An energy hazard will exist if the safety ground cable is omitted or disconnected.

##### **Mounting Instructions**

Before you install the OPN Power Supply, consult Section 3.3 of this manual to confirm that your switch supports the OPTIMAL POWER<sup>®</sup> OPN Series RPS and the respective RPS cable.

##### **Installing the OPN Power Supply on a Flat Surface**

You can install the OPN300-48SN RPS (Redundant Power Supply) on any appropriate level surface that can safely support the weight of the switches, the OPN Power Supply,

and their attached cables. There must be adequate space around the OPN Power Supply for ventilation and to access cable connectors. Consider following steps to install the RPS system on a flat surface.

- Set the OPN Power Series RPS on the flat surface and check for proper ventilation and air flow.
- Allow at least 2 inches (5.1 cm) on each side for proper ventilation and 5 inches (12.7 cm) at the back for AC and DC power-cord clearance.
- Attach rubber feet on the bottom of the chassis to keep the unit from slipping.

### Installing the OPN Power Supply in a Rack

The OPN Power Supply can be installed in most standard 19-inch racks. Consider following steps to install OPN Power Series RPS in rack.

- Use appropriate size screws to attach the RPS system to the 19-inch rack.
- Position the OPN Power Series RPS in the rack and align the oval shaped holes on the side of the RPS with the holes in the rack.
- Insert and tighten two screws appropriate for your rack through each of the oval shaped holes on the side of the RPS.

### To Operate the OPN Power Supply after Installation

Model OPN300-48SN may be installed in environments that meet the environmental characteristics specified in Chapter 2. *It is recommended that sufficient ventilation gap be provided above or below the RPS unit for proper air flow.*

Once the RPS (redundant power supply) is mounted in the rack, it should be connected to a switch (*that only requires -48VDC power*) and has a DC connector located on rear panel as shown:

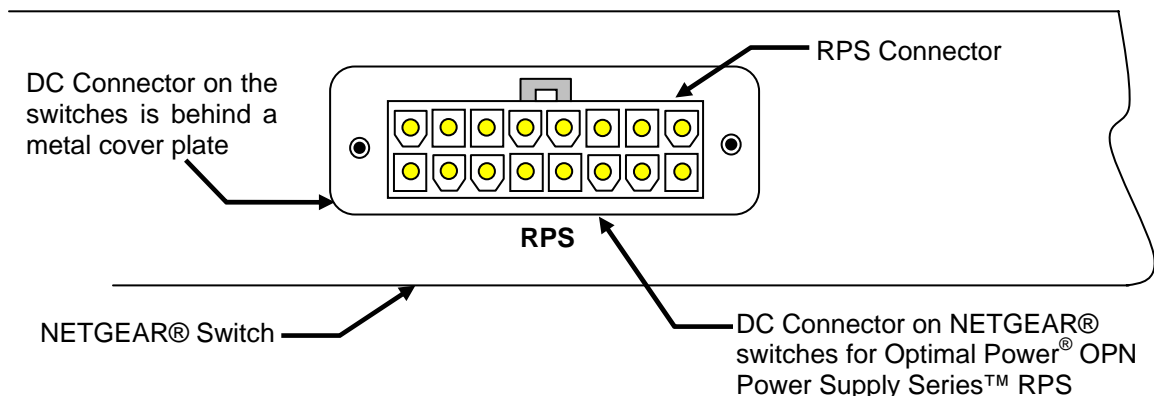

The figure shows where to connect the Optimal Power® RPS Model OPN300-48SN on the NETGEAR® switch Models FSM7326P, FSM7328PS and FSM7352PS

*Note: The location of the redundant power supply connector on your switch may differ from the illustration.*

Next follow the instructions below:

- To connect a redundant power supply (RPS) unit to the switch, first turn "OFF" the NETGEAR® Ethernet switch.
- Also, ensure that the power switch on the RPS unit OPN300-48SN is in "OFF" position.

**Important Note: Always Turn "OFF" the AC power first when installing or removing the RPS from the system. RPS device should not be live inserted. That is, when AC is "ON" do not connect the RPS cable to the RPS connector on the switch.**

- When the power is "OFF", you can remove the cover plate on the rear panel of the switch as shown on the previous page.
- Now connect the RPS DC Connection Cable Model OPNC30048 (or) OPNC300148 to the appropriate NETGEAR® Ethernet switch making sure the connections are well secured, and the AC power is "OFF".

**WARNING: Observe polarity when making connection to the rear of RPS Model OPN300-48SN**

- Connect the AC power cord to the RPS unit by plugging the free end of the power cord into a standard three prong AC outlet.
- Ensure that the AC power plug located at the rear end of the power supply is connected to a clean and well-grounded Universal AC source.
- Once all the wires are connected properly, Turn "ON" the rear panel switch for the RPS (redundant power supply) unit.
- The Green LED should light up. Indicating Power supply is "ON" and working properly. Now the system is ready to operate to its required purpose.

## 5.2 Maintenance & Safety Instructions

Please use the following safety instructions to ensure your own personal safety and to help protect your system from potential damage.

- The Model OPN300-48SN should be treated with the sufficient care.
- Do not open, service or repair any product by yourself.
- Do not use abrasives or solvents, as they may mar surfaces.
- Do not subject the unit to excessive temperature extremes.
- Do not subject the unit to excessive moisture or spilled liquids.
- Do not expose your system to direct heat, radiators, rain, dripping or splashing.
- Do not subject the unit to sudden or severe shocks.
- Never operate the Model OPN300-48SN with any of the covers removed.
- Do not block cooling vents.

- Do not push any objects into the openings of your system. Doing so can cause fire or electric shock by shorting out interior components.
- Use the product only with approved equipment.
- Operate the product only from the type of external power source specified.
- Use only approved power cable(s). If you have not been provided with a power cable contact OPTIMAL POWER<sup>®</sup>.
- To help prevent electric shock, plug the system and peripheral power cables into properly grounded electrical outlets. Provided AC cable is equipped with three-prong plugs to help ensure proper grounding.
- Do not use adapter plugs or remove the grounding prong from a cable. If you must use an extension cable, use a 3-wire cable with properly grounded plugs.
- Observe extension cable and power strip ratings.
- Make sure that the total ampere rating of all products plugged into the extension cable or power strip does not exceed 80 percent of the ampere ratings limit for the extension cable or power strip.
- To help protect your system from sudden, transient increases and decreases in electrical power, use a surge suppressor, line conditioner, or uninterruptible power supply (UPS).
- Position system cables and power cables (AC and DC) carefully; route cables so that they cannot be stepped on or tripped over. Be sure that nothing rests on any cable.
- Do not modify power cables or plugs.
- Install the power supply before connecting the power cable to the power supply.
- Unplug the power cable before removing the power supply.
- If the system has multiple sources of power, disconnect power from the system by unplugging all power cables from the power supplies.
- A qualified electrician must perform all connections to AC and DC power and to safety grounds. All electrical wiring must comply with applicable local or national codes and practices.
- Never defeat the ground conductor or operate the equipment in the absence of a suitably installed ground conductor. Contact the appropriate electrical inspection authority or an electrician if you are uncertain that suitable grounding is available.

### **5.3 Trouble-Shooting Instructions**

If the RPS system is not working, check the following steps before calling the Authorized Technician at Optimal Power<sup>®</sup>:

- Check that Green Status LED is "ON".
- Check that AC input power exists and that main switch is in the "ON" position.
- Check that the required 6A@250V fuse at the back of the RPS is not blown.
- Check that all the RPS DC Connection Cable Models OPNC30048 (or) OPNC30148 are connected and well secured.

If after all these trouble shooting steps the unit does not start, do not try to repair the unit but call the Technical Support in United States at 251-209-8088 x 22.

## 5.4 Warnings

To reduce the risk of fire, electric shock or product damage, **DO NOT** expose the Model OPN300-48SN to direct heat, rain, moisture, dripping or splashing. **DO NOT** place any object filled with any kinds of liquids on the unit. To prevent damage to LEDs and switches, **DO NOT** place the front panel of the unit face down. **DO NOT** press against the front and/or rear panel.

*Optimal Power Supplies LLC is not responsible for any kinds of damages (direct or indirect) sustained through the use of any of its products.*

## 5.5 Limited Warranties and Return Policy

Optimal Power Supplies LLC warrants all of its products against defects in materials and workmanship for one year from date of delivery. We will repair, or replace parts which prove to be defective during the warranty period provided that:

- 1) A Return Maintenance Authorization (RMA) is obtained from OPTIMAL POWER<sup>®</sup> at (251) 209-8088 or [www.optimal-power.com](http://www.optimal-power.com) Please reference your RMA number on the outside of the box the item is shipped in.
- 2) Shipping charges are pre-paid by customer.

Optimal Power does not endorse any other warranty, expressed or implied, and is not liable for consequential damages. Products that are damaged due to external causes such as accident, abuse, misuse, or problems with electrical power, opened, or modified do not qualify for a warranty. All terms specified in our website are final. Terms are subject to change. The same procedures must be followed for repairs outside the warranty period.

You may return our product with the original receipt via UPS or insured parcel post paid for by you, the customer. The product must be undamaged; there is no refund for a product that has been damaged. Large orders are not refundable. There is no refund on components and or obsolete components.

All returns must include a Return Material Authorization (RMA) number, which can be obtained by Phone or e-mail. Any package returned without prior authorization will not be accepted.

Optimal-Power is not responsible for customs charges, which include duties, taxes, brokerage fees, etc.; these are the sole responsibility of the customer recipient.

Optimal-Power will charge 25% restocking fee if the product is returned undamaged within 30 days of purchase. Please note there is **NO** return after 30 days.

**6.1 OPNC30048 and OPNC30148**

