

OPTIMAL POWER®

OPR Power Series™
AC to DC POWER SUPPLY SERIES WITH REMOTE MANAGEMENT AND
ALARM SYSTEMS

Model Nos. OPR075-12S / OPR075-12R

Manual

Revision G

July 2009

Optimal Power Supplies LLC
www.optimal-power.com

PROPRIETARY DATA

All data in this manual is proprietary and may not be disclosed, duplicated or used for procurement or manufacturing purposes, without prior written permission by
OPTIMAL POWER SUPPLIES LLC

LIABILITY

DO NOT OPERATE OR SERVICE THE OPR075-12S & OPR075-12R MODELS WITHOUT READING THIS ENTIRE MANUAL FIRST

Optimal Power Supplies LLC is not responsible for any kinds of damages sustained through the use of this or any other Optimal Power Supplies LLC products. It is entirely the customer's responsibility to take all the necessary precautionary measures when installing this unit.

In the interest of improving internal design, operational function, and/or reliability, Optimal Power Supplies LLC reserves the right to make changes to the products described in this document without notice.

WARRANTY

Optimal Power warrants all of its products against defects in materials and workmanship for one year from date of delivery. We will repair, or replace parts which prove to be defective during the warranty period provided that:

1. A Return Maintenance Authorization (RMA) is obtained from OPTIMAL POWER at (251) 209-8088 or www.optimal-power.com. Please reference your RMA number on the outside of the box the item is shipped in.
2. Shipping charges are pre-paid by customer

Optimal Power does not endorse any other warranty, expressed or implied, and is not liable for consequential damages. Products that are damaged, opened, or modified do not qualify for a warranty. The same procedures must be followed for repairs outside the warranty period.

CHAPTER	TITLE	PAGE
1	OPR Power Series – Introduction	1
1.1	Product Description.....	1
1.2	Main Features.....	1
1.3	General OPR Power Series Specifications.....	2
1.4	Typical Safety Rating.....	2
2	OPR075-12S / OPR075-12R.....	3
2.1	OPR075-12S / OPR075-12R Description.....	3
2.2	Specifications	3
3	Status Indicators and Back Panel Connections.....	5
3.1	Back Panel DC Power Connector.....	5
3.2	Front Panel Status Indicators.....	5
3.3	Remote Management DB-25 Pin Out for OPR075-12S	5
3.4	Remote Management DB-25 Pin Out for OPR075-12R	5
4	Alarm Systems.....	6
4.1	Alarm Monitoring System.....	6
5	Installation and Maintenance.....	7
5.1	Installation.....	7
5.2	Maintenance.....	7
5.3	Warnings.....	8
5.4	Design Block Diagram.....	9
6	Images.....	10
6.1	OPR075-12S (Single Power Supply).....	10
6.2	OPR075-12R (Redundant Power Supply).....	10
6.3	OPR075-12R (Front View).....	11
6.4	OPR075-12S (Front View).....	11
6.5	OPR075-12S (Rear View).....	12
6.6	OPR075-12R (Rear View).....	12
6.7	DC Cable Image.....	13

Chapter 1

OPR Power Series - Introduction

1.1 Product Description

OPR Power Series is a unique and a highly reliable power supply series. It can be configured as a single as well as a fully redundant power supply. OPR Power Series is designed for Universal AC to DC power supply applications. Because of this feature these power supplies can be used anywhere in the world. These power supplies are mainly used in the following applications:

- Computer Peripherals and Networking Applications
- Telecommunications and Fiber Optic Network
- Voice, Data and Analog Communications
- Universities and Educational Facilities
- Instrumentation and Electronics
- Utility and Power Industries
- Data Acquisition
- Medical
- Military

OPR Power Series is a reliable, efficient and inexpensive solution for all kind of AC to DC power supply applications.

1.2 Main Features:

- Compact Rack Mount Size (1.75" H x 19" W x 12.12" D)
- Universal AC (Alternate Current) Input
- Filtered IEC AC Inlet Connectors
- Internal Power Bricks EMI FCC Class B Clearance
- Single and Multiple Output
- Highly Efficient Design
- 1U Low Profile Height
- NO Minimum Load Required
- Logic Interface Remote Management
- Low Voltage Power Supply Alarm
- Cost Effective and Reliable Power Supply Solution

1.3 General OPR Power Series Specifications:

Input Voltage.....	Universal 90VAC to 264VAC
Input Frequency.....	47Hz to 63Hz
Operational Temperature.....	0°C to 55°C
Storage Temperature.....	-20°C to 85°C
Cooling.....	Cool Air Flow
Overload Protection.....	Auto-Recovery
Efficiency.....	80-90% Typical
DC OK.....	DB25 Interface and Status LEDs

1.4 Typical Safety Rating for Internal Power Modules:

Designed in full compliance with.....	UL60950
	CSA 22.2 No. 234
	EN60950
EMI.....	EN55022 “Class B”
EMS.....	EN61000-4-2,-3,-4,-5,-6,-8,-11
Harmonics.....	EN61000-3-2 Class D



Redundant Power Supply

Chapter 2

OPR075-12S / OPR075-12R

2.1 OPR075-12S / OPR075-12R Description:

The Models OPR075-12S and OPR075-12R are 1U rack mountable power supplies designed to operate in single and redundant power configurations respectively. OPR075-12S has one built-in universal AC to 12V DC power supply, and OPR075-12R has two built-in universal AC to 12V DC power supplies with two IEC AC plugs for complete redundancy. OPR075-12S provides up to 75W of power, and OPR075-12R provides up to 150W of redundant power* to the system that each is attached. Each model has its own AC-INLET (one for OPR075-12S and two for OPR075-12R for redundancy), ON/OFF switches, and power LEDs (one for OPR075-12S and two for OPR075-12R). Both models have two built-in alarm circuits with red LEDs for low DC power monitoring and for remote power management. In addition, models OPR075-12S and OPR075-12R have Logic Interface for power supply alarm and remote Turn-OFF features.

2.2 Specifications:

Electrical

Output Voltage	12V DC
Output Ripple	Typical 100 mV
Output Current	6.3A maximum
Output Power	150W for OPR075-12R* 75W for OPR075-12S
Input Voltage	Universal 90VAC to 264VAC input (2 AC inlet plugs in OPR075-12R for complete redundancy)
Input Frequency	47Hz to 63Hz
Input Current	3 Amps max
Current Tolerance	1%
Remote Management Interface	Logic Interface

Note*: 150W is intended only for redundancy; it is not recommended to power a total load of 150W with the Model OPR075-12R

Typical Safety Ratings for Internal Modules:

Designed in full compliance with	UL60950 CSA 22.2 No. 234 EN60950
EMI	EN55022 "Class B"
EMS	EN61000-4-2,-3,-4,-5,-6,-8,-11
Harmonics	EN61000-3-2 Class D

Environmental

Overload Protection	Auto-recovery
Functional Temperature	0 to 70 °C
Storage Temperature	-20 to 85 °C
Over voltage Type	Latch off
Efficiency	80-90% Typical

Physical

Dimensions	1U (1.75" H x 19" W x 12.12" D)
Weight	Approx. 13.25 lb = 6.01 kg = 212 oz



Single Power Supply

Status Indicators and Back Panel Connections

3.1 Back Panel DC Power Connector

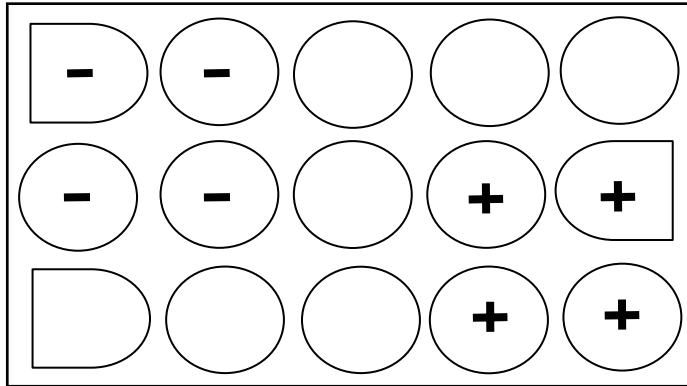

WARNING: Observe polarity when making connection to the rear of Model OPR075-12S / Model OPR075-12R

+ Indicates 12 Volt DC
- Indicates Ground Line

3.2 Front Panel Status Indicators

LED	Description (When Lit)	Labeled Indicators
Solid Green	Power Supply 1 Activated	Power 1
Solid Red	Power Supply Failure	PS 1 Alarm
Solid Green	Power Supply 2 Activated	Power 2
Solid Red	Power Supply Failure	PS 2 Alarm

3.3 Remote Management DB25 Pin Out for OPR075-12S

Pin Numbers	Description	I/O Direction	Logic High = 1	Logic Low = 0
Pin # 2	Remote Turn ON/OFF	Input	Power OFF ¹	Power ON
Pin # 3	Power Supply Alarm	+RS485Output	Alarm	No Alarm
Pin # 16	Power Supply Alarm	-RS485 Output	No Alarm	Alarm
Pin # 1	Frame Ground	Output	NA	NA
Pin # 7	Signal Ground ²	Output	NA	NA

3.4 Remote Management DB25 Pin Out for OPR075-12R

Pin Numbers	Description	I/O Direction	Logic High = 1	Logic Low = 0
Pin # 3	Power Supply 1 Alarm	+RS485Output	Alarm	No Alarm
Pin # 16	Power Supply 1 Alarm	-RS485 Output	No Alarm	Alarm
Pin # 9	Power Supply 2 Alarm	-RS485Output	No Alarm	Alarm
Pin # 17	Power Supply 2 Alarm	+RS485 Output	Alarm	No Alarm
Pin # 1	Frame Ground	Output	NA	NA
Pin # 7	Signal Ground ²	Output	NA	NA

Note 1: In order to turn OFF the power supply remotely, a voltage level of 5V @80mA current should be applied between pin 2 and pin 7.

Note 2: For proper remote management interface functionality. It is importance to connect the signal ground properly and securely.

Chapter 4 Alarm Systems

4.1 Alarm Monitoring System

The Models OPR075-12S and OPR075-12R have the ability to monitor output DC voltage, and trigger an alarm when the output DC voltage starts to decrease below the threshold limit. The power supply models have a threshold limit of 10VDC.

OPR075-12S Alarm Indications

If for some reason the voltages in power supply Model OPR075-12S drop below the threshold limit (due to overload, for example) the DB25 interface pin 16 will go logic LOW, and pin 3 will have logic HIGH indicating power supply failure.

DB25 Pin Out	Normal Condition		Power Supply Failure	
Pin 16 (Power Supply Alarm)	Logic High = 1	↑	Logic Low = 0	↓
Pin 3 (Power Supply Alarm)	Logic Low = 0	↓	Logic High = 1	↑

OPR075-12R Alarm Indications

If for some reason the voltages of power supply 1 in the Model OPR075-12R drop below the threshold limit (due to overload, for example) the DB25 interface pins 3 will go logic HIGH, and pin 16 will have logic LOW indicating power supply 1 failure.

DB25 Pin Out	Normal Condition		Power Supply Failure	
Pin 3 (Power Supply 1 Alarm)	Logic Low = 0	↓	Logic High = 1	↑
Pin 16 (Power Supply 1 Alarm)	Logic High = 1	↑	Logic Low = 0	↓

Furthermore, if the voltages of power supply 2 drop below the threshold limit. The interface pin 17 will go logic HIGH, and pin 9 will have LOW indicating power supply 2 failure.

DB25 Pin Out	Normal Condition		Power Supply Failure	
Pin 17 (Power Supply 2 Alarm)	Logic Low = 0	↓	Logic High = 1	↑
Pin 9 (Power Supply 2 Alarm)	Logic High = 1	↑	Logic Low = 0	↓

Chapter 5

Installation and Maintenance

5.1 Installation

OPR075-12S and OPR075-12R may be installed in a fixed, semi-fixed and mobile environments that meet the environmental characteristics specified in Chapter 2. These models are designed to be mounted in a standard 19" equipment rack utilizing the mounting holes provided on the front of each unit. **It is recommended that at least 1 rack unit (1U = 1.75") gap be provided above or below the OPR power supply unit for proper air flow.**

Once these power supplies are mounted in the rack, they should be connected to the system (that only requires 12V DC power) with the DC output connector located at the rear of the OPR unit.

WARNING: Observe polarity when making connection to the rear of model OPR075-12S / OPR075-12R

- Next, ensure that the front panel power switch(es) are in "OFF" position.
- Connect the AC power cord to the unit by plugging the free end of the power cord into a standard three prong AC outlet.
- Ensure that the AC power plug(s) located at the rear end of the power supply are connected to a clean and well-grounded Universal AC source.

OPR075-12S Setup

Once all the wires are connected properly as described in the above installation paragraph:

- (1) Turn "ON" the front panel switch.
- (2) The "Power" LEDs, should light up.

Now the system is ready to operate to its required purpose.

OPR075-12R Setup

Once all the wires are connected properly as described in the above installation paragraph:

- (1) Turn "ON" the front panel switch for Power supply 1

The "Power 1" green LED, and "PS 2 Alarm" red LED should light up. Indicating Power supply 1 is "ON" and Power supply 2 is "OFF"

- (2) Turn "ON" the front panel switch for Power supply 2

This should clear the "PS 2 Alarm" red LED and cause the "Power 2" green LED to illuminate.

Now the system is ready to operate to its required purpose.

Monitoring AC Input and DC Output

OPR Series models have switches that monitor AC current input and DC current output. Whenever the “Power” switches are “ON”, the LEDs embedded in the switch should light up. These indicate good AC input. Similarly the “Power 1” (or “Power1” and “Power2” in redundant models) LEDs should turn green, indicating good DC output.

Alarm Conditions for Redundant Power Supply

- Power 1 Failure
- AC plug disconnected to Power 1
- Front panel Switch to Power 1 is in “OFF” position
- Power 2 Failure
- AC Plug disconnected to Power 2
- Front panel Switch to Power 2 is in “OFF” position

5.2 Maintenance

The Models OPR075-12S and OPR075-12R should be treated with the sufficient care.

- Do not use abrasives or solvents, as they may mar surfaces
- Do not subject the unit to excessive temperature extremes
- Do not subject the unit to excessive moisture or spilled liquids
- Do not subject the unit to sudden or severe shocks
- Never operate the Model OPR075-12S / OPR075-12R with any of the covers removed

5.3 Warnings

To reduce the risk of fire, electric shock or product damage, **DO NOT** expose the OPR075-12S / OPR075-12R unit(s) to direct heat, rain, moisture, dripping or splashing. **DO NOT** place any object filled with any kinds of liquids on the unit(s). To prevent damage to LEDs and switches, **DO NOT** place the front panel of the unit face down, and/or **DO NOT** press against the front panel.

Optimal Power is not responsible for any kinds of damages sustained through the use of this product.

5.4 Design Block Diagram

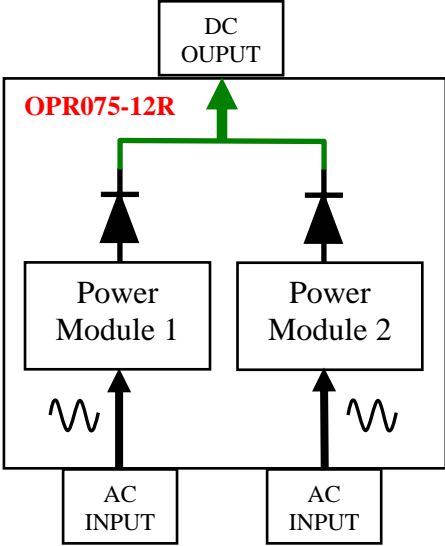
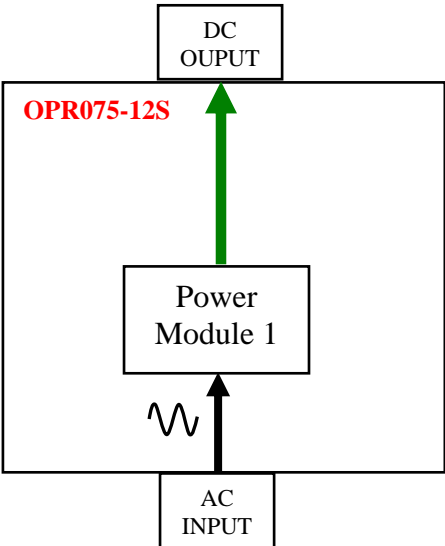

6.1 OPR075-12S (Single Power Supply)

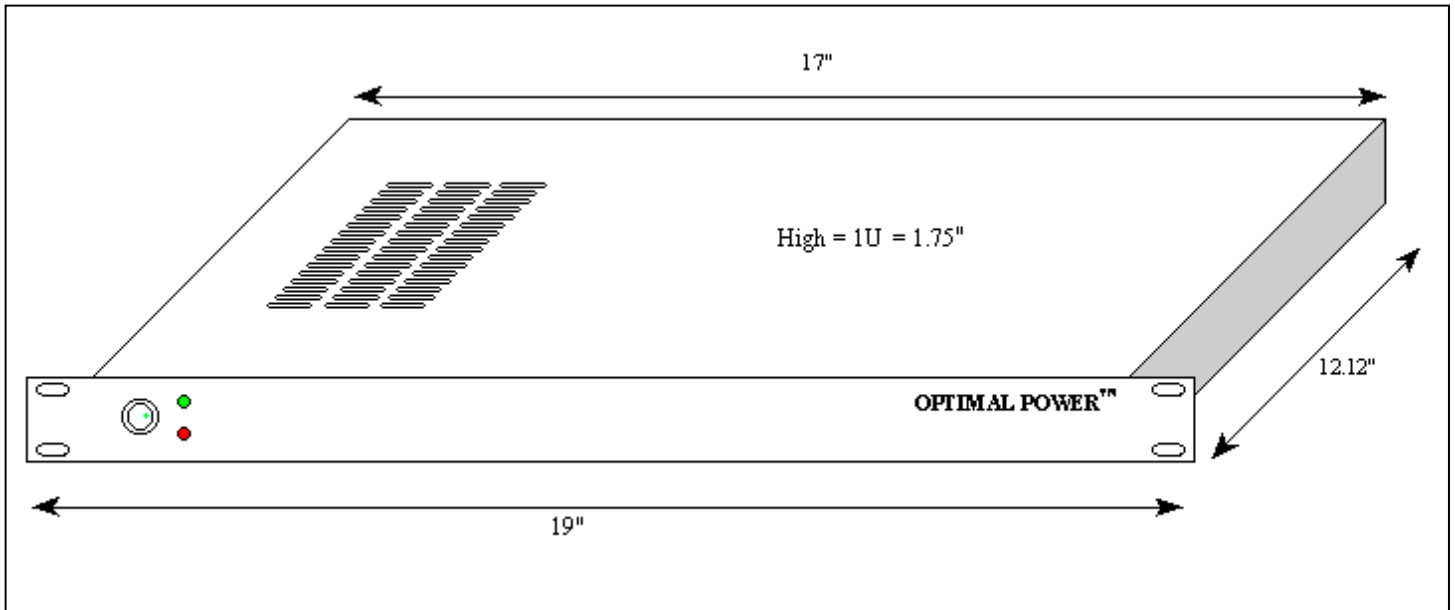

6.2 OPR075-12R (Redundant Power Supply)

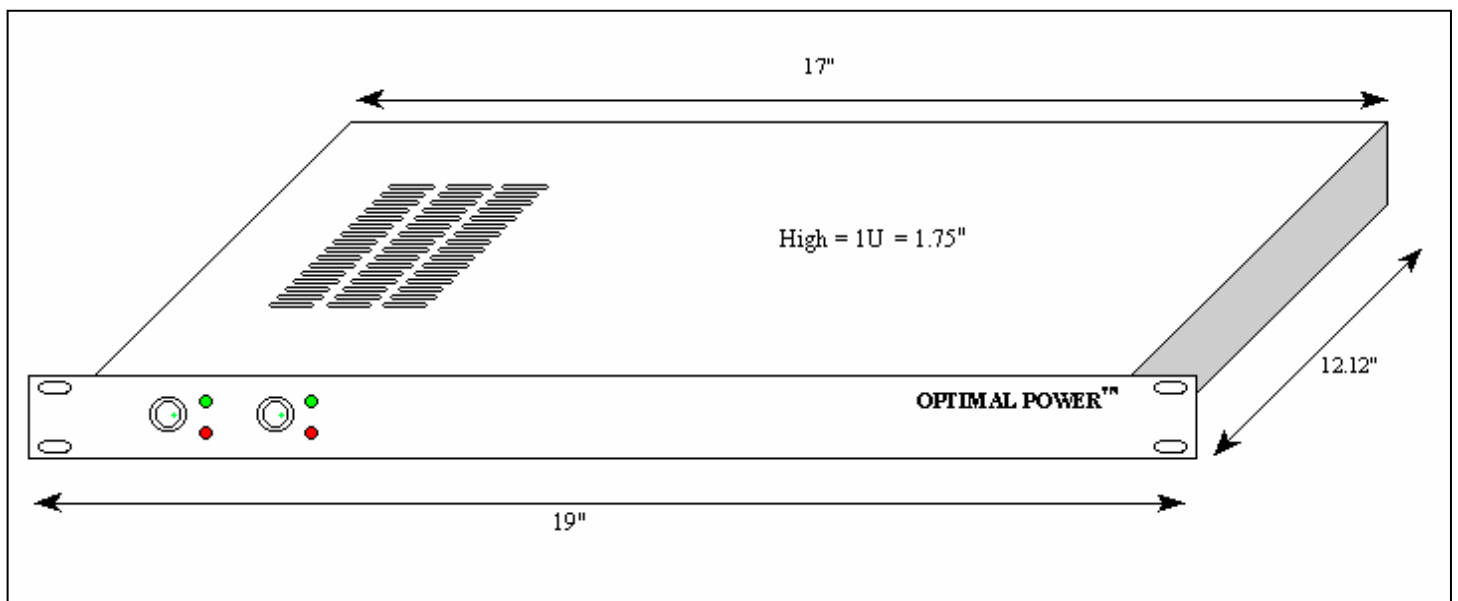

6.3 OPR075-12R (Front View)

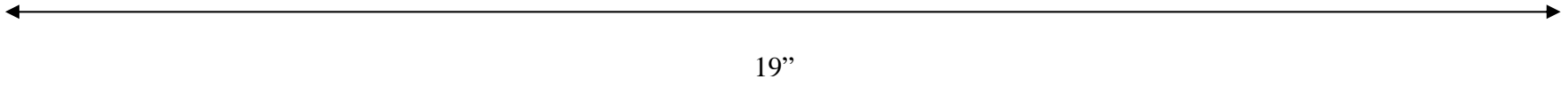

6.4 OPR075-12S (Front View)

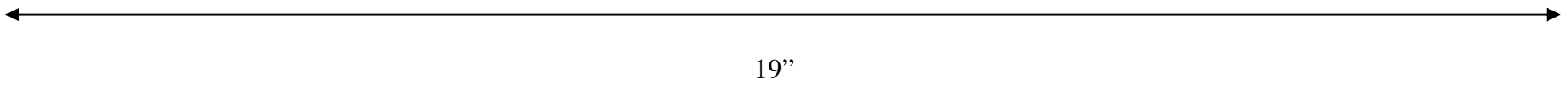
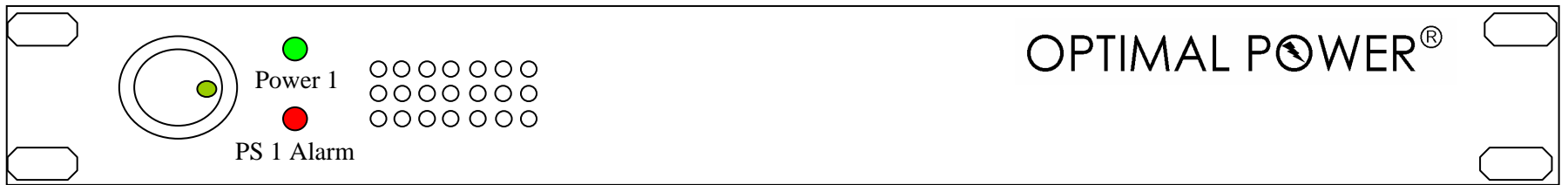

6.5 OPR075-12S (Rear View)

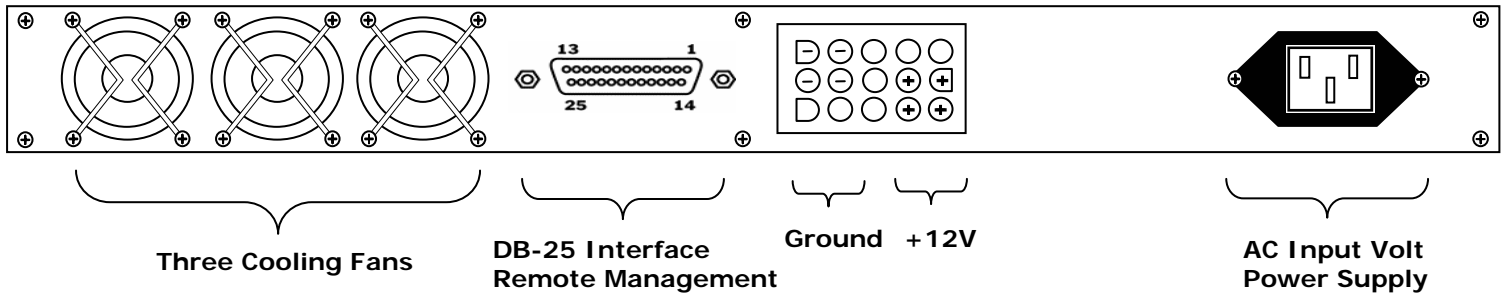

Pin 1 = Frame Ground
 Pin 2 = Remote ON/OFF
 Pin 3 = Power Alarm
 Pin 7 = Signal Ground
 Pin 16 = Power Alarm

6.6 OPR075-12R (Rear View)

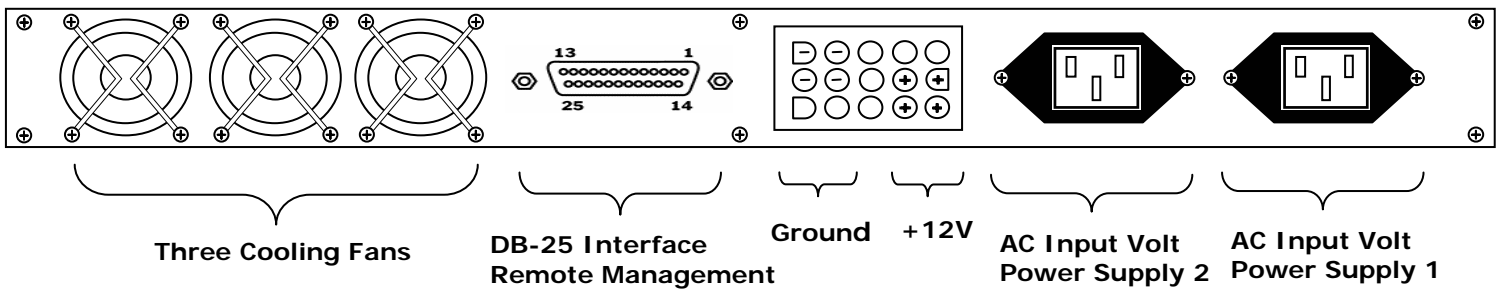

Pin 1 = Frame Ground
 Pin 3 = Power 1 Alarm
 Pin 16 = Power 1 Alarm
 Pin 9 = Power 2 Alarm
 Pin 17 = Power 2 Alarm
 Pin 7 = Signal Ground

6.7 DC Cable Image

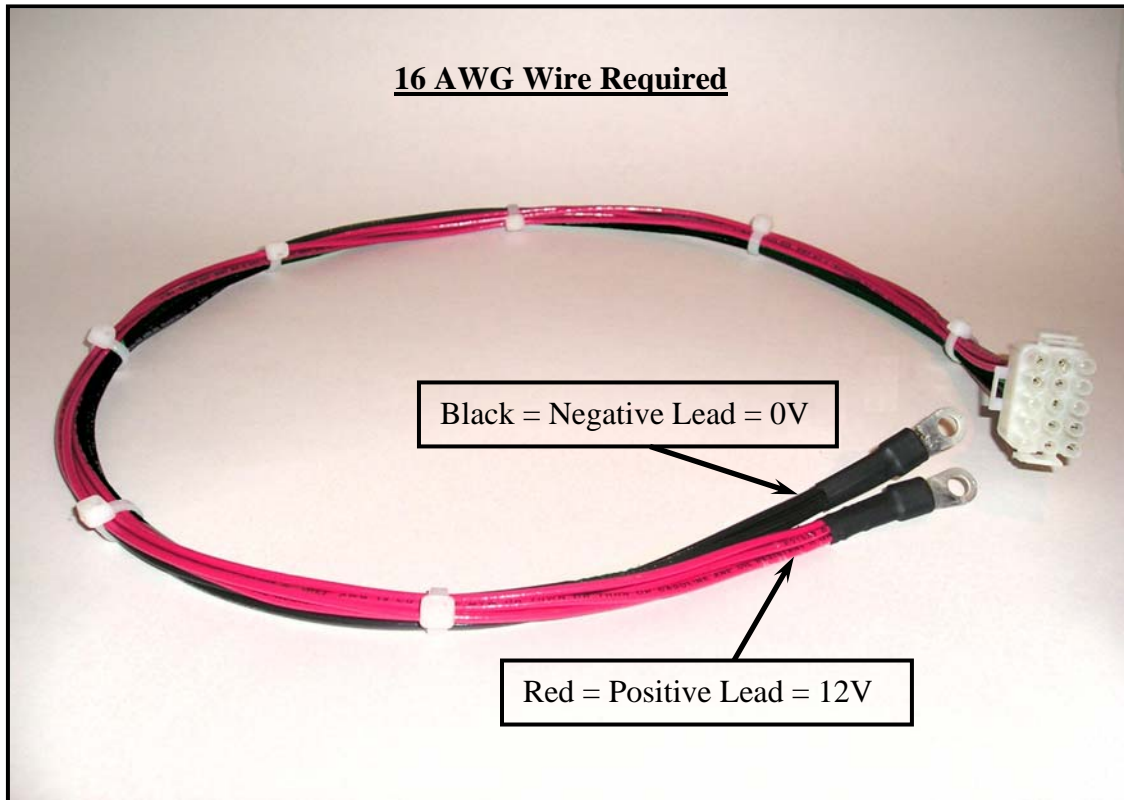

Important Note* For proper current flow make sure to connect all the specified power terminals

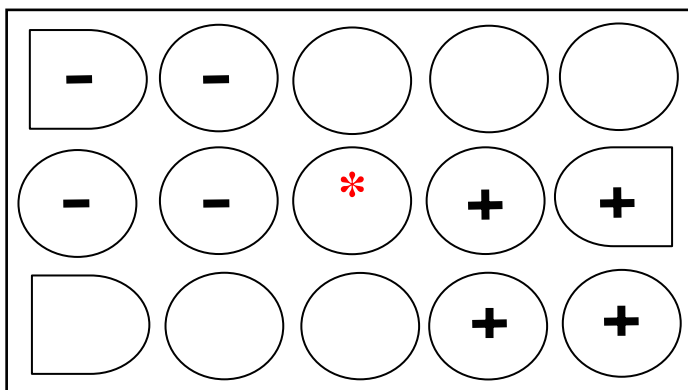

WARNING: Observe polarity when making connection to the rear of Model OPR075-12S / Model OPR075-12R

+ Indicates 12 Volt DC
- Indicates Ground Line